

HM9B

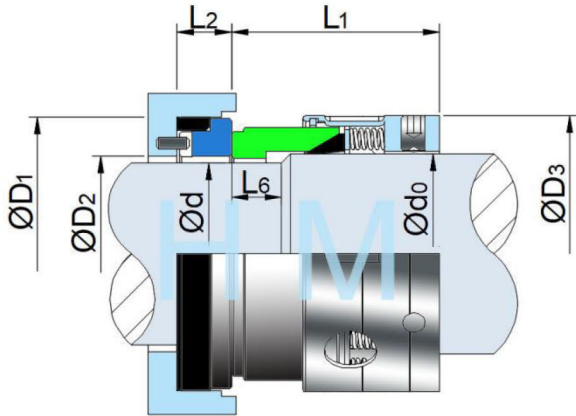

Type : Multi Spring Mechanical Seal
 Replacement: vulcan 1609B , AES M02 , Crane 109B/9B
 Temperature: -40°C to +250°C
 Pressure: ≤ 2.5 Mpa
 Speed: ≤ 15 m/s
 Material: V1,Q1,Q2,U2,B,A,P,E,V,M1,M2,F,G,M

Size (Inch)	d0	d	D3	D2	D1	L1	L2	L6
1.000	25.4	22.2	40.10	22.9	38.10	33.32	10.3	6.4
1.125	28.5	25.4	43.36	26.1	41.28	34.93	11.1	7.9
1.250	31.7	28.5	48.13	29.3	44.45	34.93	11.1	7.9
1.375	34.9	28.5	51.30	29.3	44.45	36.50	11.1	8.7
1.500	38.1	31.7	54.48	32.4	47.63	36.50	11.1	8.7
1.625	41.2	34.9	60.83	35.6	50.80	44.45	11.1	8.7
1.750	44.4	38.1	64.00	38.8	53.98	44.45	11.1	9.5
1.875	47.6	41.2	66.68	42.4	60.33	44.45	12.7	9.5
2.000	50.8	44.4	70.36	45.5	63.50	44.45	12.7	9.5
2.125	53.9	47.6	76.70	48.7	66.68	52.37	12.7	11.1
2.250	57.1	50.8	79.88	51.9	69.85	52.37	12.7	11.1
2.375	60.3	53.9	83.06	55.0	76.20	52.37	14.3	11.1
2.500	63.5	57.1	86.23	58.2	79.38	52.37	14.3	11.1
2.625	66.6	60.3	89.40	61.4	82.55	52.37	14.3	11.1
2.750	69.8	63.5	92.58	64.6	85.73	52.37	14.3	11.1
2.875	73.0	66.6	95.76	67.7	85.73	52.37	15.9	11.1
3.000	76.2	69.8	97.33	70.9	88.90	52.37	15.9	11.1
3.125	79.3	73.0	100.50	74.1	95.25	52.37	15.9	11.1
3.250	82.5	76.2	105.28	77.3	98.43	52.37	15.9	14.3
3.375	85.7	79.3	108.46	80.5	101.6	52.37	19.8	14.3
3.500	88.9	82.5	111.63	83.6	104.78	52.37	19.8	14.3
3.625	92.0	85.7	114.80	86.8	107.95	52.37	19.8	14.3
3.750	95.2	88.9	117.98	90.0	111.13	52.37	19.8	14.3
3.875	98.4	92.0	121.16	93.1	114.30	52.37	19.8	14.3
4.000	101.6	95.2	124.33	96.3	117.48	52.37	19.8	14.3