

# HM26

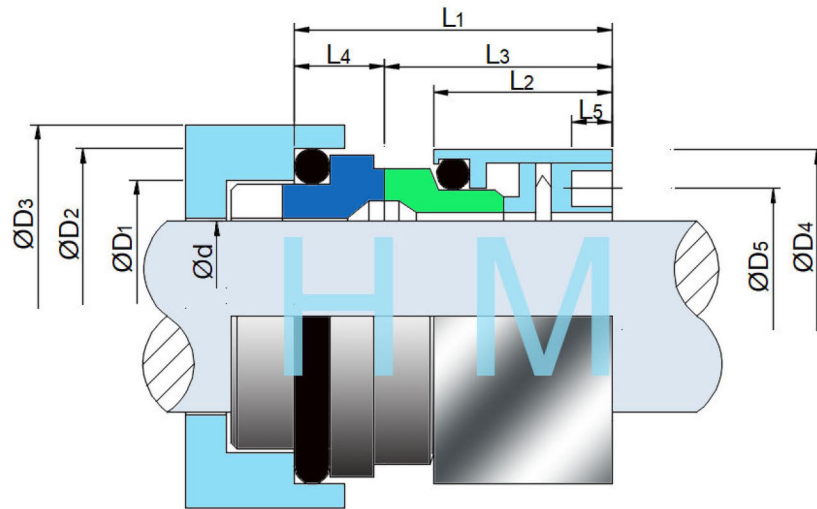

Type : Multi-Spring Seal  
 Replacement: Lidering 26  
 Temperature: -20 to +140°C  
 Pressure : ≤4.0Mpa  
 Speed: ≤10m/s  
 Material : B,Q2,U2,P,E,N,V,F,G,Alfa



d (mm)	D1	D2	D3	D4	D5	L1	L2	L3	L4	L5
40	53.5	59.0	65	65	52	48.5	30.0	39.0	9.5	5
50	63.5	72.0	75	75	61	54.5	33.0	42.2	12.3	5
53	66.5	75.0	80	80	64	55.0	33.5	42.7	12.3	5
55	71.5	80.0	85	85	68	60.0	36.5	47.2	12.8	5
60	76.5	85.0	90	90	74	61.5	38.0	47.7	12.8	5
65	81.5	90.0	95	95	78	62.0	38.0	49.2	12.8	5
80	102.0	110.5	115	115	98	63.5	38.0	50.0	13.5	5

