

HMW03S

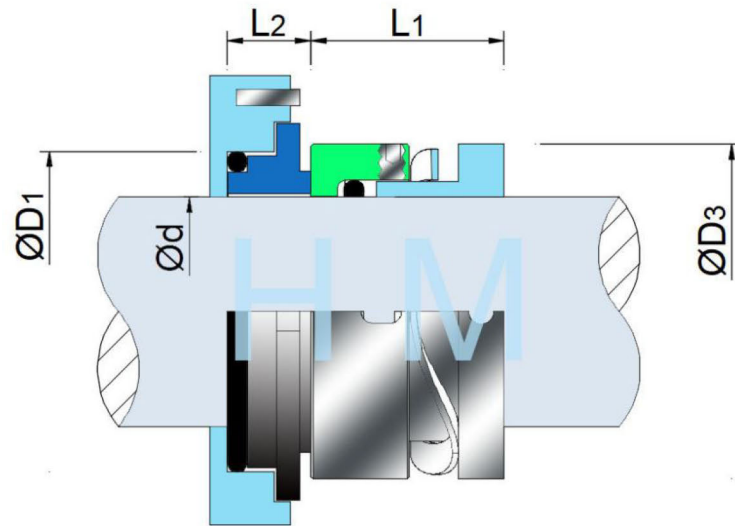

Type : Wave Spring Mechanical Seal
 Replacement: AES W03S , Vulcan
 1688W , Crane87(EI/EC)
 Temperature : -40°C to +200°C
 Pressure : ≤ 0.8 Mpa
 Speed : ≤ 18 m/s
 Material: Q2,B,U2,P,E,V,F,G



PUMP ref:	d (mm)	D1	D3	L1	L2
SR1	20	30.0	32.4	20.0	10.7
SR2	30	41.3	44.0	21.4	10.9
SR3	35	47.0	50.8	22.0	12.2
SR4	45	58.3	62.4	22.9	11.6
SR5	55	69.6	76.0	29.3	13.0
SR6	75	92.2	99.2	31.1	14.5