

HMWB2A/WB2B

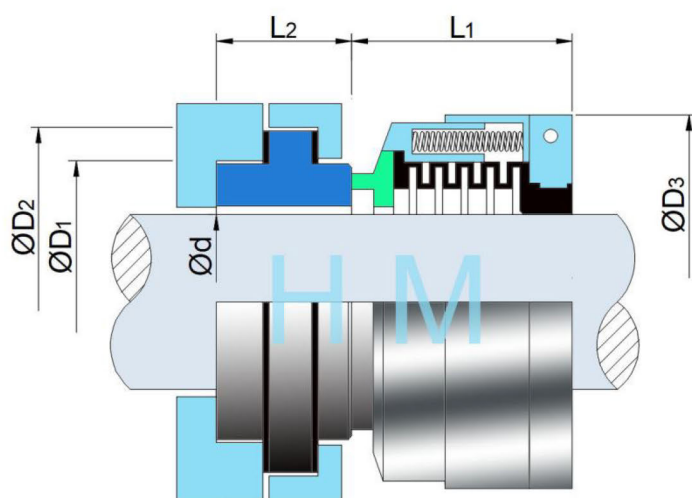

Type: PTFE Bellow Mechanical Seal
 Replacement: Crane WB2
 Temperature: -20°C to $+120^{\circ}\text{C}$
 Pressure: $\leq 0.5\text{Mpa}$
 Speed: $\leq 10\text{m/s}$
 Material: Q2, V2, F, G, TEFLON

HMWB2-XXA



HMWB2-XXB

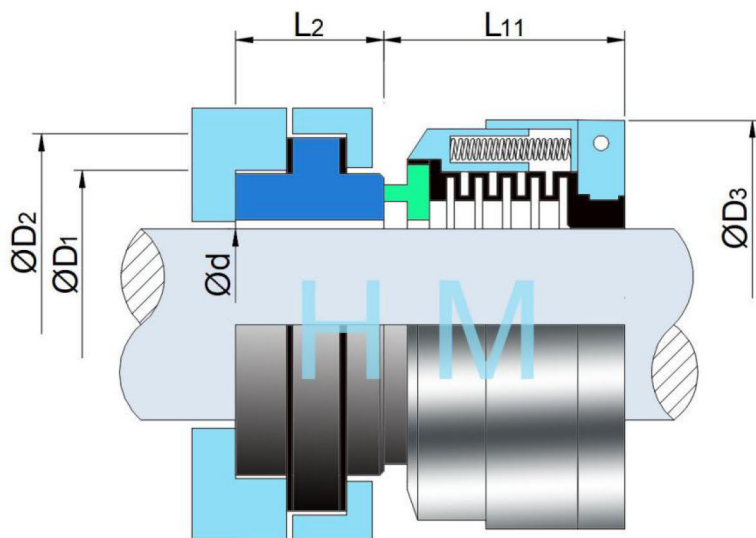

HMWB2A/WB2B

d (mm)	D1	D2	D3	L1	L2	L11
25	47	60	60	42	27	45
30	53	67	67	42	27	45
32	50.7	64	69	42	27	45
35	57	70	72	42	27	45
40	62	76	78	42	26	45
45	67	82	84	44	27	46
50	72	86	88	46	27	46
55	77	90	95	46	27	46
60	82	95	100	46	27	46
65	87	100	105	46	27	46

d (Inch)	D1	D2	D3	L1	L2	L11
25.40	42.86	54	60	42	17.5	45
28.60	46.03	60	67	42	27.0	45
31.75	50.80	65	69	42	27.0	45
34.93	53.98	68	72	42	27.0	45
38.10	57.15	71	76	42	27.0	45
41.28	63.50	78	80	42	27.0	45
44.45	66.68	81	84	44	27.0	46
47.63	69.85	84	86	44	27.0	46
50.80	73.03	87	90	46	27.0	46
53.98	79.38	97	95	46	33.5	46
57.15	82.55	100	98	46	33.5	46
60.30	85.73	103	100	46	33.5	46