

HMCS-A56(CSS)

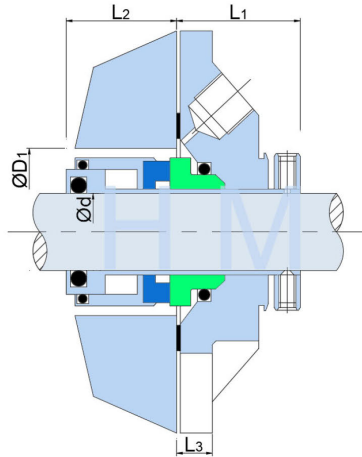

Type: Single Cartridge Seal
 Replacement: AES CSS
 Temperature: -30°C to +205°C
 Pressure: ≤ 2.1 Mpa
 Speed: ≤ 25 m/s
 Material: B,A,Q1,Q2,U2,E,V,K,F,G,M

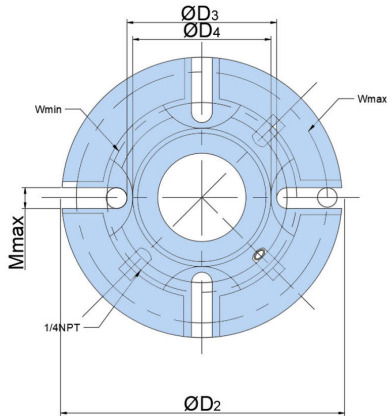

hengmi@meseal.com

d (mm)	D1			D2	D3	D	W		M max	L1	L2	L3
	min	mint	max				min	max				
90	114.3	115.8	127	215.9	150.8	127	171.5	195.2	20	49.2	31.8	19.6
95	117.5	119	130.2	215.9	150.8	127	171.5	195.2	20	49.2	31.8	19.6
100	123.9	125.4	139.7	228.6	168.3	136.5	188.9	207.9	20	49.2	31.8	19.6
105	130.1	131.6	149.2	228.6	168.3	136.5	159	208	20	49.2	31.8	19.6
110	136.5	138	158.8	241.3	177.8	146.1	198.4	220.6	20	49.2	31.8	19.6
115	142.9	144.4	168.3	254	186.6	155.6	211.1	230.2	22	49.2	31.8	19.6
120	142.9	144.4	168.3	254	186.6	155.6	211.1	230.2	22	49.2	31.8	19.6

d (inch)	D1			D2	D3	D4	W		M max	L1	L2	L3
	min	mint	max				min	max				
3.625	4.500	4.560	5.000	8.5	5.937	5.000	6.750	7.687	42433	1.937	1.25	0.769
3.750	4.625	4.685	5.125	8.5	5.937	5.000	6.750	7.687	42433	1.937	1.25	0.769
3.875	4.750	4.810	5.250	8.5	5.937	5.000	6.750	7.687	42433	1.937	1.25	0.769
4.000	4.875	4.935	5.500	9.0	6.625	5.375	7.437	8.187	42433	1.937	1.25	0.769
4.125	5.125	5.185	5.875	9.0	6.625	5.375	7.437	8.187	42433	1.937	1.25	0.769
4.250	5.125	5.185	5.875	9.0	6.625	5.375	7.437	8.187	42433	1.937	1.25	0.769
4.375	5.375	5.435	6.250	9.5	7.000	5.750	7.812	8.687	42433	1.937	1.25	0.769
4.500	5.375	5.435	6.250	9.5	7.000	5.750	7.812	8.687	42433	1.937	1.25	0.769
4.625	5.625	5.685	6.625	10.0	7.345	6.125	8.312	9.062	42559	1.937	1.25	0.769
4.750	5.625	5.685	6.625	10.0	7.345	6.125	8.312	9.062	42559	1.937	1.25	0.769