

HMCS-FT05(C2D)

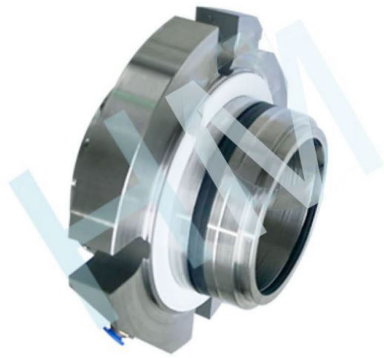

Type: Double Cartridge Seal,
Recommended for high duty service.

Replacement: Fluiten C2D

Temperature: -40 to +260°C

Pressure: ≤ 25 Bar

Speed: ≤ 12 m/s

Material: Q1, Q2, U2, T, V, M1, F, G, M

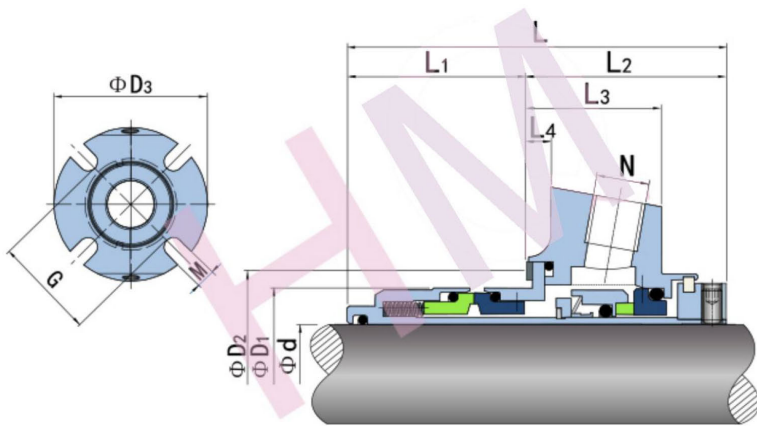

hengmi@mesal.com

d (mm)	D1	D2		D5	G	L	L1	L2	L3	L4	M	N
		min	max									
25	43	44.0	51.0	98	63	94.0	44.5	49.5	33.5	6	12	1/4"
28	46	47.0	52.0	98	28	94.0	44.5	49.5	33.5	6	12	1/4"
30	48	49.0	56.0	98	65	94.0	44.5	49.5	33.5	6	12	1/4"
32	50	51.0	57.0	106	67	94.0	44.5	49.5	33.5	6	12	1/4"
33	53	54.0	61.5	106	71	97.5	44.5	53.0	36.0	6	12	1/4"
35	53	54.0	61.5	106	71	97.5	44.5	53.0	36.0	6	12	1/4"
38	56	57.0	66.0	120	76	98.5	44.5	54.0	37.0	6	12	1/4"
40	58	59.0	68.0	120	76	98.5	44.5	54.0	37.0	6	12	1/4"
43	61	62.0	70.5	130	81	98.5	44.5	54.0	37.0	6	12	1/4"
45	63	64.0	73.0	135	81	98.5	44.5	54.0	37.0	6	12	1/4"
48	66	67.0	75.0	135	87	98.5	44.5	54.0	37.0	6	12	1/4"
50	68	69.0	78.0	148	87	100.5	44.5	56.0	39.0	6	12	1/4"
55	73	74.0	83.0	148	95	102.0	44.5	57.5	40.0	6	18	1/4"
60	78	79.0	91.0	158	102	102.0	44.5	57.5	40.0	6	18	3/8"
65	83	84.5	98.5	163	112	102.0	44.5	57.5	40.0	6	18	3/8"
70	93	95.0	108.0	178	125	107.0	44.5	62.5	45.0	6	18	3/8"
75	98	100.0	113.0	185	130	107.0	44.5	62.5	45.0	6	18	3/8"
80	105	107.0	118.0	193	135	121.0	52.0	69.0	49.0	6	18	3/8"
85	110	113.0	123.0	198	140	121.0	52.0	69.0	49.0	6	22	3/8"
90	115	118.0	130.0	205	145	121.0	52.0	69.0	49.0	6	22	3/8"
95	121	124.0	135.0	209	150	123.0	54.0	69.0	49.0	6	22	3/8"
100	126	129.0	140.0	218	155	123.0	54.0	69.0	49.0	6	22	3/8"