

# HMCS-FT02(C2KC)

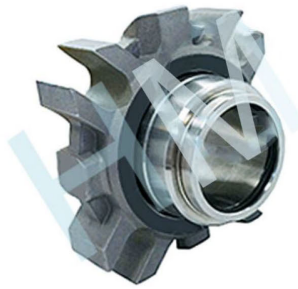

Type: Single Cartridge Seal with connection for flushing, Recommended for low duty service.

Replacement: Fluiten C2 KC

Temperature: -40 to +180°C

Pressure : ≤15.0Bar

Speed: ≤12m/s

Material : Q1,Q2,U2,T,V,M1,F,G,M

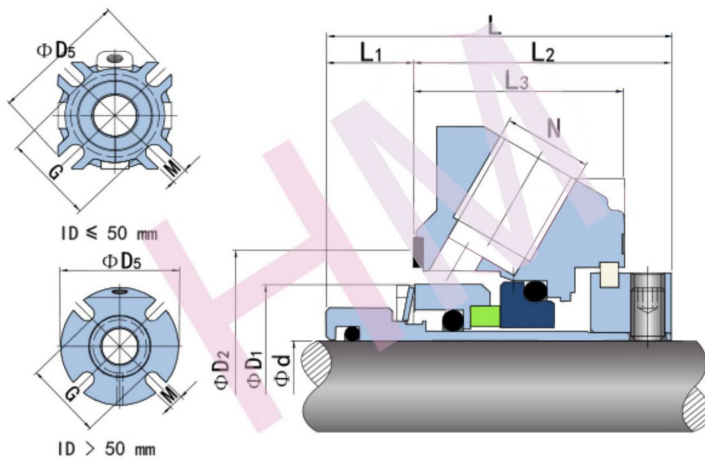

[hengmi@mes seal.com](mailto:hengmi@mes seal.com)

d (mm)	D1	D2		D5	G	L	L1	L2	L3	M	N
		min	max								
25	42	44	53	98	63	51.5	13.0	38.5	31.5	12	1/4"
28	45	47	53	98	63	51.5	13.0	38.5	31.5	12	1/4"
30	47	49	55	98	65	51.5	13.0	38.5	31.5	12	1/4"
33	54	56	60	106	68	55.0	15.5	39.5	31.5	12	1/4"
35	54	56	60	106	68	55.0	15.5	39.5	31.5	12	1/4"
38	57	59	68	120	76	56.0	16.5	39.5	31.5	14	1/4"
40	59	61	68	120	76	56.0	16.5	39.5	31.5	14	1/4"
43	62	64	73	135	81	56.0	16.5	39.5	31.5	14	1/4"
45	64	66	73	135	81	56.0	16.5	39.5	31.5	14	1/4"
48	67	69	79	148	87	56.0	16.5	39.5	31.5	14	3/8"
50	69	71	79	148	87	59.0	19.5	39.5	31.5	14	3/8"
55	78	80	84	148	95	60.5	20.5	40.0	31.5	18	3/8"
60	83	85	92	158	102	60.5	20.5	40.0	31.5	18	3/8"
65	88	90	102	163	112	60.5	20.5	40.0	31.5	18	3/8"
70	99	101	112	178	125	64.5	24.5	40.0	31.5	18	3/8"
75	104	106	117	185	130	64.5	24.5	40.0	31.5	18	3/8"
80	109	111	122	193	135	70.0	24.5	45.5	35.0	18	3/8"
85	114	116	126	198	140	70.0	24.5	45.5	35.0	22	3/8"
90	119	121	134	205	145	70.0	24.5	45.5	35.0	22	3/8"
95	124	126	139	209	150	70.0	24.5	45.5	35.0	22	3/8"
100	129	131	144	218	155	70.0	24.5	45.5	35.0	22	3/8"