

AL-12(W03)



Type : Suit for Alfa Laval SRU(SSP,SR),NMOG

Pumps

Replacement : AES W03, Vulcan 1688W, Crane 87(EI/EC)

Temperature : -40°C to +200°C

Pressure : $\leq 0.8\text{Mpa}$

Speed : $\leq 18\text{m/s}$

Material : A,B,Q1,Q2,P,E,V,F,G

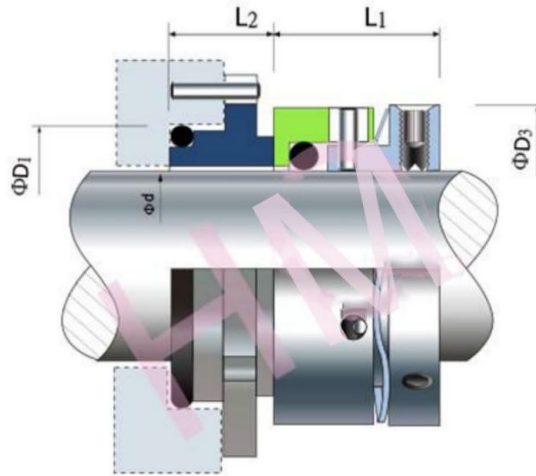

PUMP ref:	Size (Metric)	D1	D3	L1	L2
SR1	20	30	31.0	19.1	10.7
SR2	30	41	41.0	19.1	10.9
SR3	35	47	45.5	21.1	12.2
SR4	45	58	58.2	21.1	11.6
SR5	55	70	72.0	22.1	13.0
SR6	75	92	96.0	25.8	14.5

