

AL-26(W09)



Type: Suit for Alfa Laval MOG

600,1000,2000,3000 Series,(SSP 12,M2)

Pumps

Replacement: AES W09

Temperature: -45°C to +150°C

Pressure : ≤ 3.5 Mpa

Speed: ≤ 15 m/s

Material: F,G,P,E,V

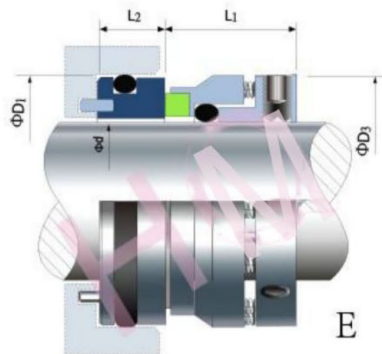
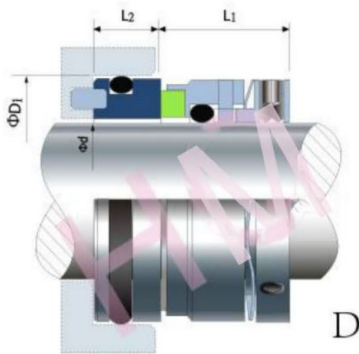
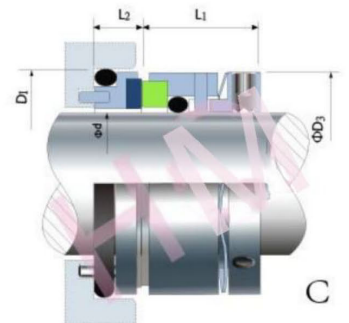
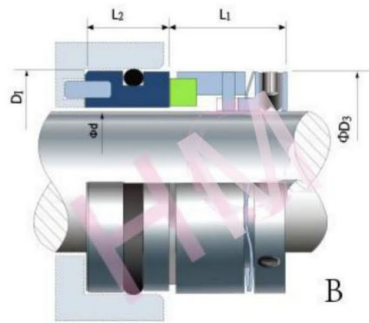
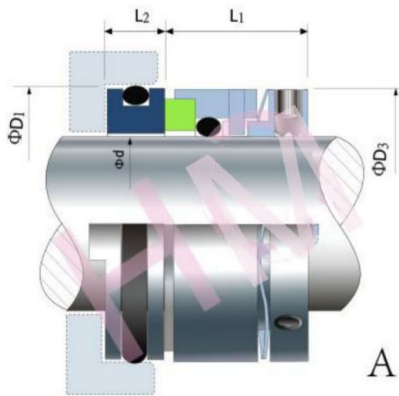

hengmi@meseal.com

Type	d	D1	D3	L1	L2
A	15.0	27.0	26.0	20.9	9.3
B	30.1	42.0	40.9	20.6	14.0
B	34.9	47.6	46.7	20.6	15.8
C	34.9	47.6	46.7	20.6	7.9
D	50.8	66.6	65.4	23.8	11.9
E	76.2	95.2	98.6	39.7	11.9