

APV-11(W09-CL)

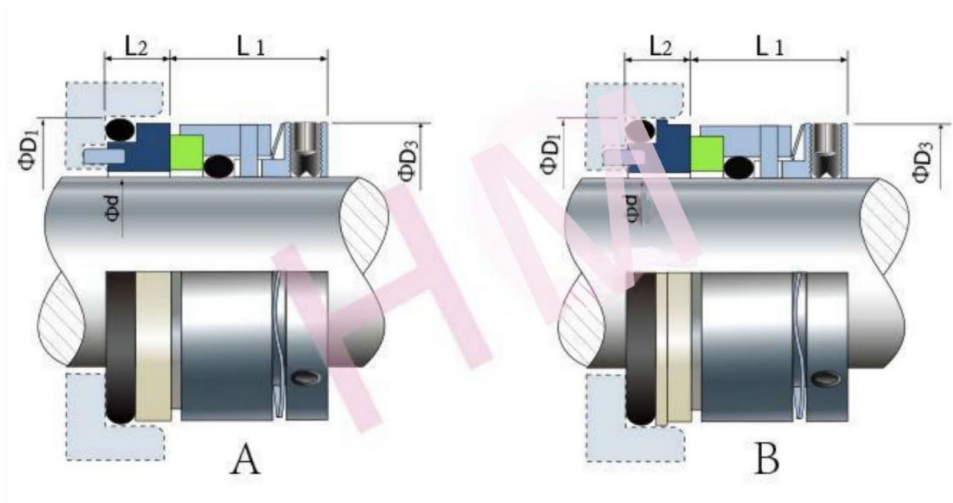

Type: Suit for APV HOWARD CL Pumps
 Replacement: AES W09-CL
 Temperature: 0°C to +100°C
 Pressure: ≤ 3.0 Mpa
 Speed: ≤ 10 m/s
 Material : B,A1,Q1,Q2,U2,P,E,N,V,F,G,



Type	d	D1	D3	L1	L2
A	28.6	41.2	40.2	20.6	7.0
A	53.9	73.0	70.5	24.6	7.2
B	47.6	63.5	60.4	21.4	9.3

