

HMFR-5(W-3X01/2)

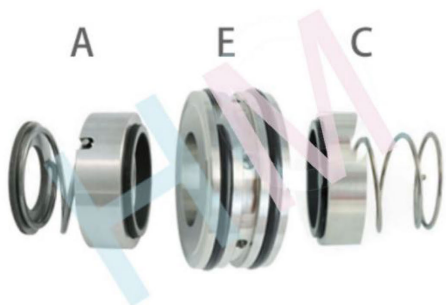

Type: Suit for FRISTAM Pumps
 Replacement : AES T01F(30mm,35mm)
 Temperature: -20°C to +180°C
 Pressure : ≤ 1.0 Mpa
 Speed: ≤ 15 m/s
 Material : B,A1,Q1,Q2,U2,P,E,N,V,F,G

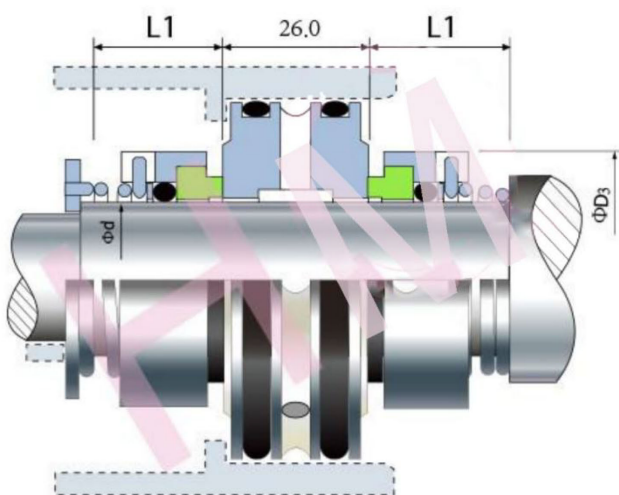

d (mm)	D3	L
30	60	26
35	70	26