

HMFR-12(T01F)



Type: Used for Food, Beverage
and Dairy in dustries

Replacement: Vulcan 2209/2, Billi BB14B

Temperature: -20°C to +180°C

Pressure : ≤ 1.0 Mpa

Speed: ≤ 15 m/s

Material : B,E,F,G

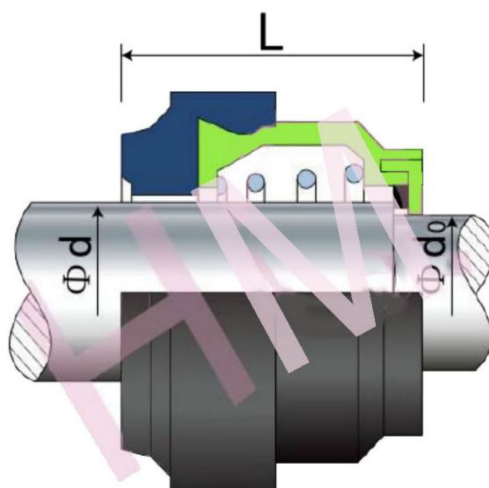

d (mm)	d0	L	Pump type
22	15	22	FP/FL/FT
30	22	24	