

HMFR-19(P09)

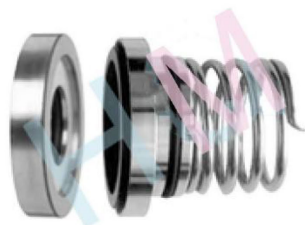

Type: Suit for FRISTAM Pumps
 Replacement: AES P09, Burgmann MR,
 Vulcan 94, Lidering FR-Z-21
 Temperature: -20°C to +200°C
 Pressure: ≤ 2.5 Mpa
 Speed: ≤ 20 m/s
 Material : B, A1, Q1, Q2, U2, P, E, N, V, F, G

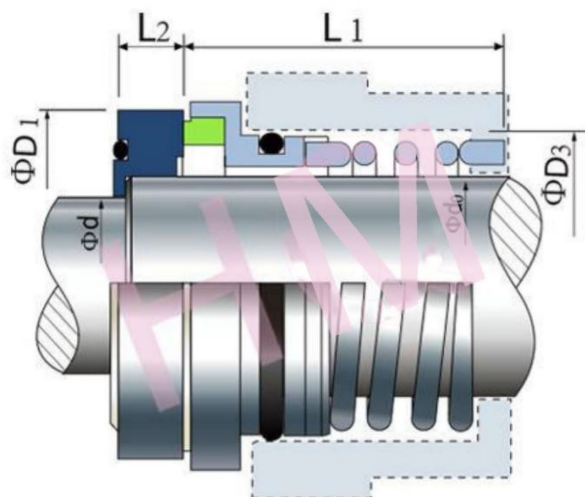

d (mm)	d0	D1	D3
21	25	59	50