

HMLZ Series

Type: Flygt Pump Seals
Replacement: AES T05 VC

HMLZ-20mm , 25mm

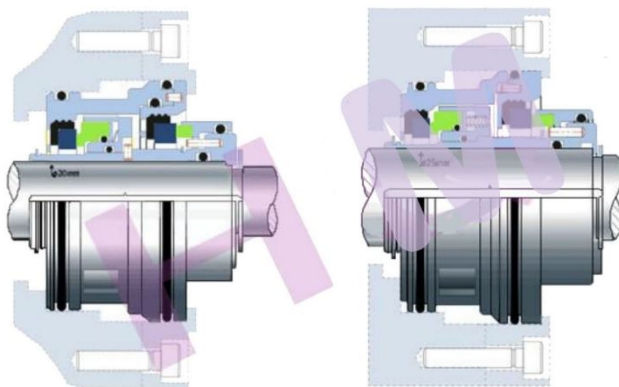

HMLZ-35mm , 45mm

HMLZ-60mm , 90mm

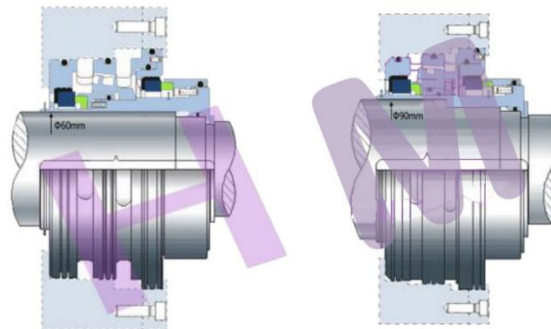
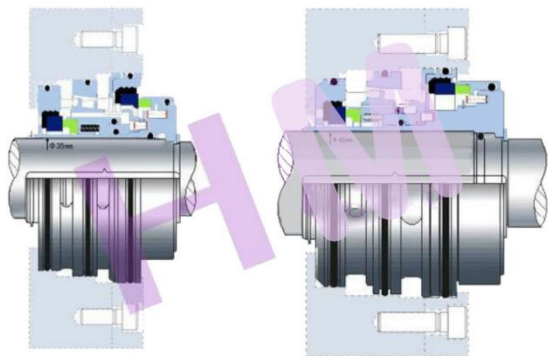

HM Seal Code	Size	Material	Fits Flygt Pumps/Mixers
HMLZ20	20mm	TC/ TC- TC/ CER/ V	2610 , 2620 , 2630 , 2640 , 4610 & 4620
HMLZ25	25mm	TC/ TC- TC/ CER/ V	2660 , 4630 & 4640
HMLZ35	35mm	TC/ TC- TC/ TC/ V	2670 , 3153 , 5100.210 , 5100.211 , 5100.220 & 5100.221
HMLZ45	45mm	TC/ TC- TC/ TC/ V	3171 , 4650 , 4660 , 5100.250 , 5100.251 , 5100.260 & 5100.261
HMLZ60	60mm	TC/ TC- TC/ TC/ V	3202 , 4670 , 4680 , 5100.300 , 5100.310 , 5150.300 & 5150.310
HMLZ90	90mm	TC/ TC- TC/ TC/ V	3301 , 5150.350 & 5150.360