

HMHID-05(41)

Type: Suit for HIDROSTAL Pumps

Replacement: Vulcan 41

Temperature: -40 to +204°C

Pressure : ≤ 2.5 Mpa

Speed: ≤ 15 m/s

Material : B,A,Q2,U2,P,E,V,F,G

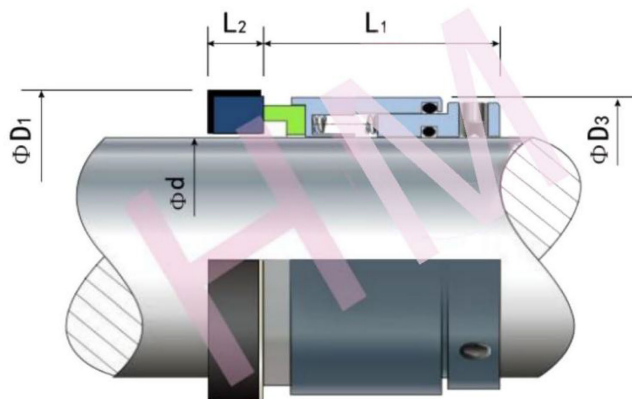

d (mm)	D1	D3	L1	L2	O.E.M
					Seal Code
25.58	44.44	44.0	30.0	8.10	M1.1
38.10	53.98	54.8	31.6	8.10	M1.5
50.80	69.85	67.6	38.1	12.70	M2.0,X2
63.50	85.73	78.3	46.2	14.28	M2.5,X2.5
76.20	98.43	93.7	52.4	15.88	M3.0,X3.0
95.00	123.85	128.0	62.9	16.50	X0.95
d (Inch)	D1	D3	L1	L2	O.E.M
					Seal Code
1.125	1.750	1.732	1.181	0.319	M1.1
1.500	2.125	2.157	1.244	0.319	M1.5
2.000	2.750	2.661	1.500	0.500	M2.0,X2
2.500	3.375	3.082	1.812	0.562	M2.5,X2.5
3.000	3.875	3.689	2.063	0.625	M3.0,X3.0
3.740	4.876	5.039	2.477	0.649	X0.95