

# HMHIL- 12(T01LFU)

Type: O-ring Mechanical Seal  
 Replacement: AES T02 LFU  
 Temperature: -20 to +140°C  
 Pressure :  $\leq 1.0\text{Mpa}$   
 Speed:  $\leq 15\text{m/s}$   
 Material : B,Q2,U2,P,E,N,V,F,G,Alfa

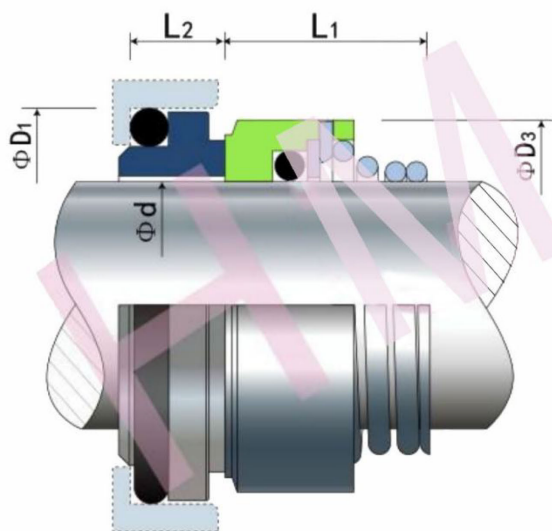
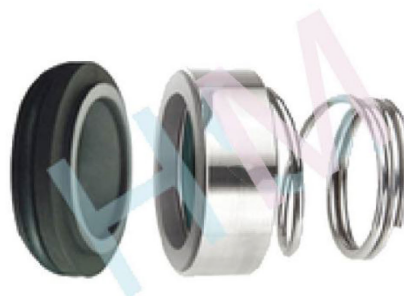

d (mm)	D1	D3	L1	L2
22	37	36	23.5	10.0
30	45	44	31.5	11.0
40	58	56	33.5	11.5
50	70	66	33.5	13.0
d (mm)	D1	D3	L1	L2
0.866	1.457	1.417	0.925	0.394
1.181	1.772	1.732	1.240	0.433
1.575	2.283	2.205	1.319	0.453
1.969	2.756	2.598	1.358	0.512