

HMINO-03(M07U)



Type: Suit for Inoxpa Prolac R,Prolac S,M25
Blender Pumps

Replacement: AES M07U,Vulcan 50,ROTEN S,ROPLAN R52

Temperature : -40°C to +200°C

Pressure : ≤0.8Mpa

Speed : ≤18m/s

Material: B,Q22,P,E,V,F,G

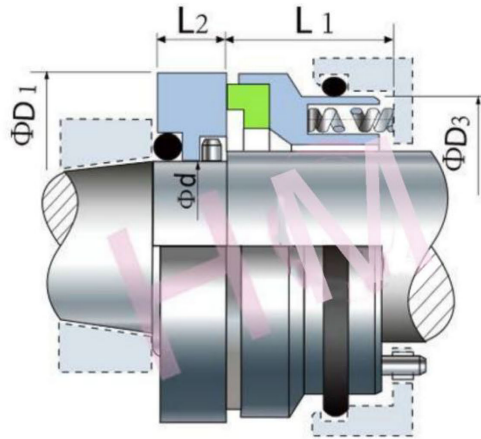

d (mm)	D1	D3	L1	L2
15.8	44.5	36.1	24	10.5
25.4	53.5	44.0	24	10.0
38.1	74.0	64.0	28	15.5
d (inch)	D1	D3	L1	L2
0.625	1.752	1.421	0.945	0.413
1.000	2.106	1.732	0.945	0.394

