

HMWAR-01



Type: Desulfurization Stirred Seal
Replacement: Match with WARMAN Pump
Temperature: -30°C to +220°C

Pressure : 2.1Mpa

Speed: ≤ 25 m/s

Material : Q1,Q2,A,B,U1,U2,P,E,V,T,F,G,T2,M5

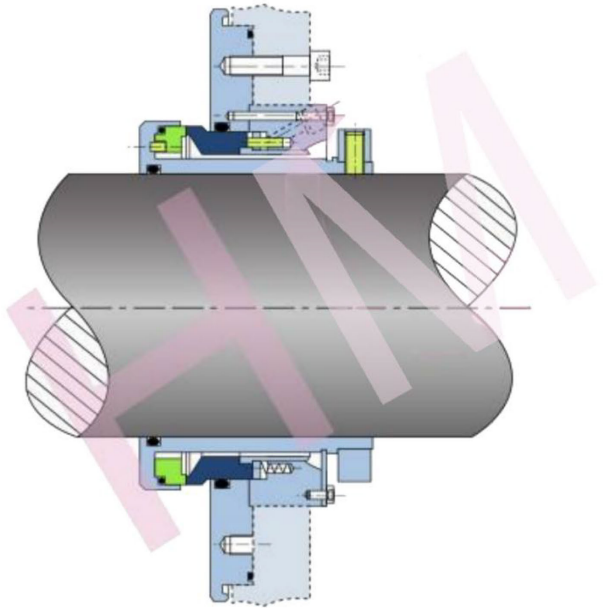

*** Product description:**

Used in main circulation pump of smog desulfurized tower in electric power plant.

*** Apply to the host:**

Match with Warman pump.

*** Axle diameter:**

165mm and 220mm available.



www.hengmiseal.com