

HMWKS-03(M09)

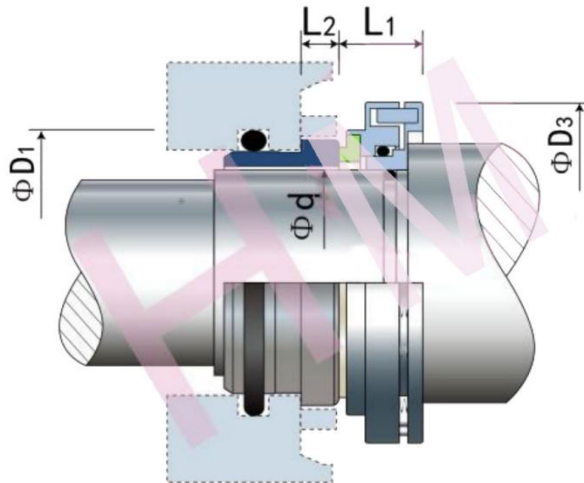

Type: Waukesha/ Wright Universal 1,
WRU(TRA10) Pump Seal
Replacement: AES M09
Temperature: -20 to +180°C
Pressure: $\leq 1.4\text{Mpa}$
Speed: $\leq 10\text{m/s}$
Material : B,Q2,U2,P,E,N,V,F,G,Alfa



d (mm)	D1	D3	L1	L2
38.1	53.6	80.8	11.6	3.0
47.6	66.1	79.0	19.4	8.9
d (inch)	D1	D3	L1	L2
1.500	2.110	3.175	0.457	0.118
1.875	2.602	3.110	0.763	0.350

