

HMOP-13(AT)



Type: Armstrong 4300 Pump Seals
Replacement: U.S VGXB2

Temperature: -20°C to +120°C

Pressure: $\leq 1.2\text{Mpa}$

Speed: $\leq 10\text{m/s}$

Material: B,A,Q1,Q2,U2,P,E,N,V,F,G

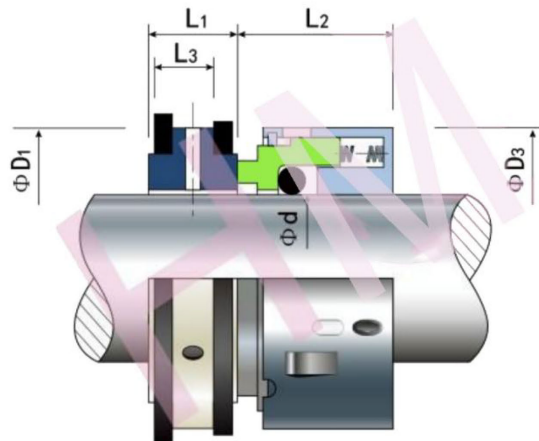

d (inch)	d (mm)	D1	D3	L1	L2	L3
1 1/8	28.575	59.4	47.6	25.3	25.6	15.9
1 5/8	41.275	71.8	62.0	25.3	29.5	15.9
2 1/8	53.975	84.6	79.4	25.3	29.3	15.9
2 5/8	66.675	111.0	88.9	25.3	41.3	15.9

